



Preliminary Datasheet

1. General Introduction

The MCCWxxx-T series of current sensors provide faster and more cost-effective solutions for AC and DC current detection in industrial and automotive applications. It also provides effective isolation between the primary and secondary edges. The same enclosure can provide a variety of current measurements from $\pm 400\text{A}$ to $\pm 900\text{A}$.

2. Features

- Open loop current sensor based on HALL induction principle
- Single power supply 5V
- Analog signal output
- With V_{REF} Input and output function
- The measuring current range of the original side can be from $\pm 400\text{A}$ - $\pm 900\text{A}$
- Sensor operating temperature range: $-40\text{ }^\circ\text{C}$ to $+125\text{ }^\circ\text{C}$
- Output voltage:
 - TR: zero current bias $V_{QVO}=V_{CC}/2$
 - TF: Zero current bias $V_{QVO}=2.5\text{ V}$
- Good accuracy, linearity and temperature drift

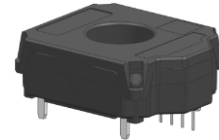

3. Applications

- EV/HEV motor controller
- Inverter, inverter control
- Power supply and DC-DC converter control

Working principle:

The open-loop current sensor uses ampoule's law (the magnetic field generated around a energized straight wire is proportional to the current in the wire), and uses the characteristics of hall device to detect the magnitude of the magnetic field intensity B generated by the current on the original side, so as to detect the current in the wire. In the linear interval of hysteresis, the proportional relation between B and I is:

$$B(I_P) = K * I_P \quad (K \text{ is a constant})$$

Hall voltage can be expressed as:

$$V_H=(R_H/d) * I * K * I_P$$

In addition to the I_P is the change, and the rest are constants, thus:

$$V_H=K_1 * I_P \quad (K_1 \text{ is a constant})$$

Specific hall chips are amplified by V_H ,So you get the voltage and you get the original current

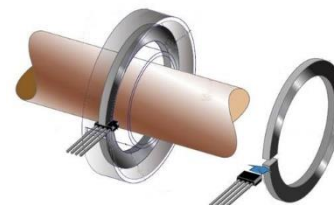

4. Maximum Rating

DC Operating Parameters : At ($T_A=25$ degree C)

Characteristic	Symbol	Rating	Unit
Supply voltage	V_{CC}	0.3 to 6.5	V
Supply current	I_{CC}	18	mA
Output voltage	V_{OUT}	0.15 to $V_{CC}-0.15$	V
Output current	I_{OUT}	+ 40	mA
Working temperature	T_A	-40 to 125	$^{\circ}C$
T_{jm}	T_J	165	$^{\circ}C$
Storage temperature	T_S	-55 to 165	$^{\circ}C$
Creepage distance	d_{CP}	3.5	mm
Isolation voltage(50Hz, 1min, AC)	U_d	2.5	KV

5. Specifications

DC Operating Parameters: $V_{CC} = 5V$

Parameter	Symbol	Condition	Min	Typ. '	Max	Unit	
Supply voltage	V_{CC}		4.5	5	5.5	V	
Supply current	I_{CC}	$R_L \geq 10K\Omega$		13	18	mA	
Power on delay	T_{PO}	$T_A=25^{\circ}C$		80		μs	
QVO follow-up error (-TR)	E_r		0.3		0.3	%	
Zero current output	V_{QVO}	HSCWxxx-TR	$T_A = 25^{\circ}C$		$V_{CC}/2,$ 2.50 ± 0.005		V
		HSCWxxx-TF					
Output voltage range @IP	$V_{OUT}-V_{QVO}$	$T_A = 25^{\circ}C, I_P=I_{P_{MAX}}$			± 2		
Load resistance	R_L	V_{OUT} to V_{CC} or GND	2			$K\Omega$	
Load capacitance	C_L	V_{OUT} TO GND	6		100	nF	
Response time	$t_{RESPONSE}$	$T_A=25^{\circ}C, C_L=1nF, I_P$ step=50% of I_{P+} , 90% input to 90% output		3		μs	
Bandwidth	BW	Small signal -3dB, $C_L=1nF, T_A=25^{\circ}C$	120	170		KHz	
Output impedance	R_{OUT}	$T_A = 25^{\circ}C$	-	3	-	Ω	

The performance parameters

V_{CC} = DC operating parameters at 5V (unless otherwise specified), T_A Within the specified temperature range.

Parameter	Symbol	Condition	Min	Typ.	Max	Unit
Nominal parameter						
Original current measurement range	I_P		-900		900	A
Calibration of current	I_{CAL}	@ $T_A=25^\circ C$	-450		450	
Sensor sensitivity	$Sens_{STA}$		2.22 ¹⁾		5.00 ¹⁾	mV/A
Accuracy parameters						
Sensitivity error	E_{Sens}	@ $T_A=25^\circ C; V_{CC}=5V$	-1		1	%
Zero offset voltage	I_{OE}	$I_P=0A, T_A=25^\circ C$	-5	± 4	5	mV
Zero offset voltage	I_{OM}	$I_P=0A, T_A=25^\circ C$, after excursion of 900A		3	5	mV
Zero offset voltage	V_{OFFSET}	$T_A=25^\circ C$		± 10		mV
Linearity error	Lin_{ERR}	Of full rang	-1	0.5	1	%

1) Please refer to the order information for the sensitivity of 400A~900A

6 · Schematic Diagram

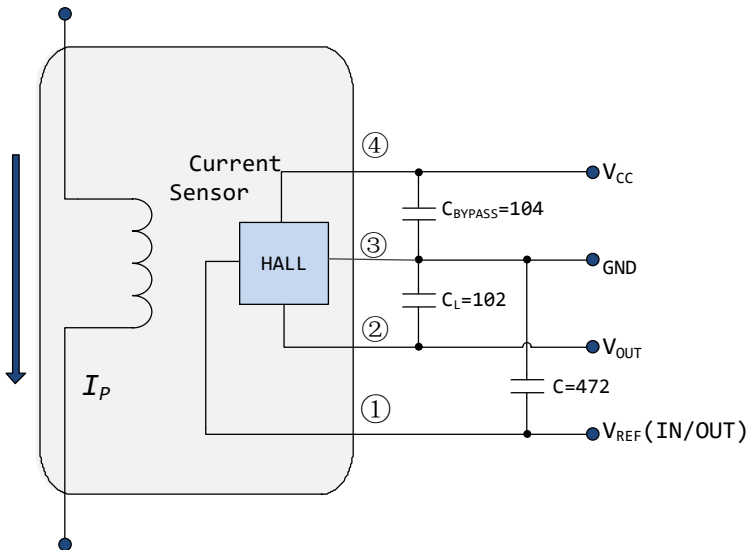

*** C_{BYPASS} The capacitance needs to be placed close to the VCC sensor**



7. Ordering Information

Model	V _{QVO}	Original edge current range I _P (A)	Sensitivity Sens (Typ.) (mV/A)	MPQ	MOQ
				(PCS)	(PCS)
MCCW400-TR	V _{CC} / 2	+ 400	5	500	500
MCCW400-TR	2.50	+ 400	5	500	500
MCCW500-TR	V _{CC} / 2	+ 500	4	500	500
MCCW500-TF	2.50	+ 500	4	500	500
MCCW600-TR	V _{CC} / 2	+ 600	3.33	500	500
MCCW600-TF	2.50	+ 600	3.33	500	500
MCCW700-TR	V _{CC} / 2	+ 700	2.86	500	500
MCCW700-TF	2.50	+ 700	2.86	500	500
MCCW800-TR	V _{CC} / 2	+ 800	2.5	500	500
MCCW800-TF	2.50	+ 800	2.5	500	500
MCCW900-TR	V _{CC} / 2	+ 900	2.22	500	500
MCCW900-TF	2.50	+ 900	2.22	500	500

* For currents outside the standard current specifications, please contact the facto

8. Definition of performance parameters

Definition of performance parameters

- **Static output voltage (QVO)** : sensor output voltage V_{QVO} in the state of no obvious magnetic field B =0G
 -TR: V_{QVO} and the supply voltage V_{CC} has a constant ratio; $V_{QVO} = V_{CC}/2$
 -TF: V_{QVO} doesn't follow the supply voltage V_{CC} within a certain range Change for change, as in V_{CC}= 4.5~5.5V, V_{QVO}=2.5 V
- **Sensitivity Sens(Sensitivity)**: Sens is the reference output straight line (-TR model: $V_{OUT} = V_{CC}/2 + 2 \times I_P/I_{P_MAX}$ -TF mode: $V_{OUT} = 2.5 + 2 \times I_P/I_{P_MAX}$), refers to the change of the output as the current changes, and it's relationship with the current is as follows: $Sens = 2/I_{P_MAX}$.
- **Offset with Temperature**: Due to tolerances, stresses and heat dissipation of internal components, zero Offset may occur at operating ambient Temperature.
- **Sensitivity with temperature**: Due to the internal temperature compensation factor, the Sensitivity will change over the entire operating temperature compared to what is expected at room temperature.
- **Electrical Offset Voltage**: The Hall component and the internal operational amplifier itself cause errors caused by the noise of amplification factor, which is called the Offset Voltage

- **Magnetic Offset** : The current on the original side is Offset by the maximum value I_P at 0, due to the hysteresis of the magnetic core material of the sensor, the error generated at the output end is called zero magnetic imbalance voltage
- **Offset voltage**: The offset voltage is the output voltage when the original edge current is zero. The ideal value is $V_{QVO} = V_{CC}/2$ (Or **2.5V**). As a result, the difference between V_{QVO} and the ideal value is called the total zero offset voltage error. This offset error can be attributed to the zero offset voltage (due to the QVO adjusted resolution within the ASIC), magnetic offset, temperature drift, and temperature induced hysteresis.
- **Rise Time**: The Rise Time of the sensor refers to the Time interval between the output of the sensor and the corresponding value of the applied current when the applied current reaches 90% of the final value
- **Rise time**: The rise time of the sensor refers to the time interval between 10% of the output of the sensor and the final 90%

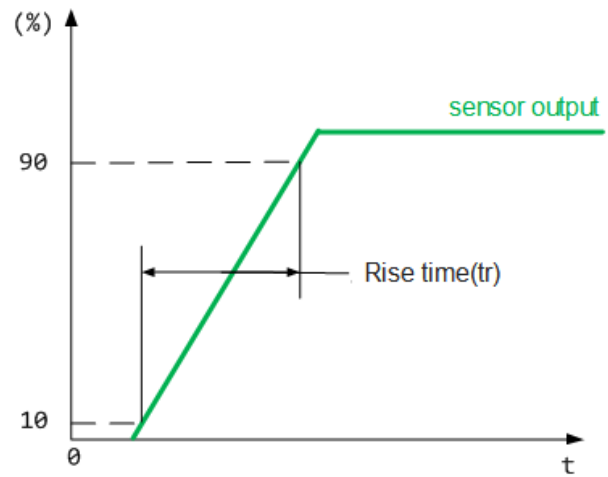
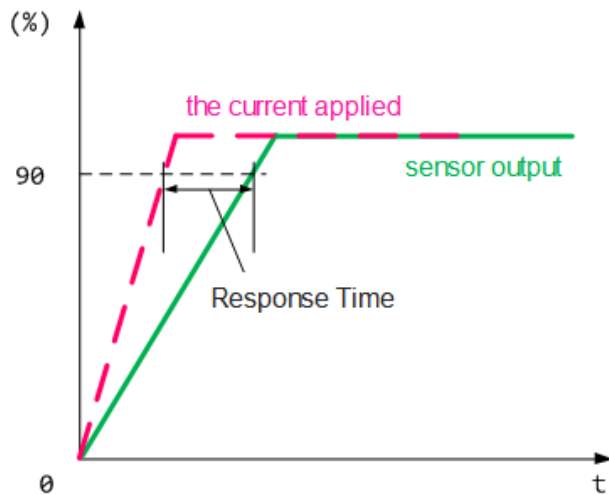

- **QVO Ratiometricity Error:** When supply voltage V_{CC} goes from 5V to $4.75 < V_{CC1} < 5.25V$, the deviation between the sensor's zero point output and the theoretical value is defined as follows:

$$E_r = \frac{V_{QVO(V_{CC1})}}{V_{QVO(5V)} - V_{CC1}/5} \times 100\%$$

- **Linearity:** Contrast with the reference output line (-TR mode: $V_{OUT} = V_{CC}/2 + 2 \times I_P/I_{P_MAX}$ -TF mode: $V_{OUT} = 2.5 + 2 \times I_P/I_{P_MAX}$), the largest forward or reverse error

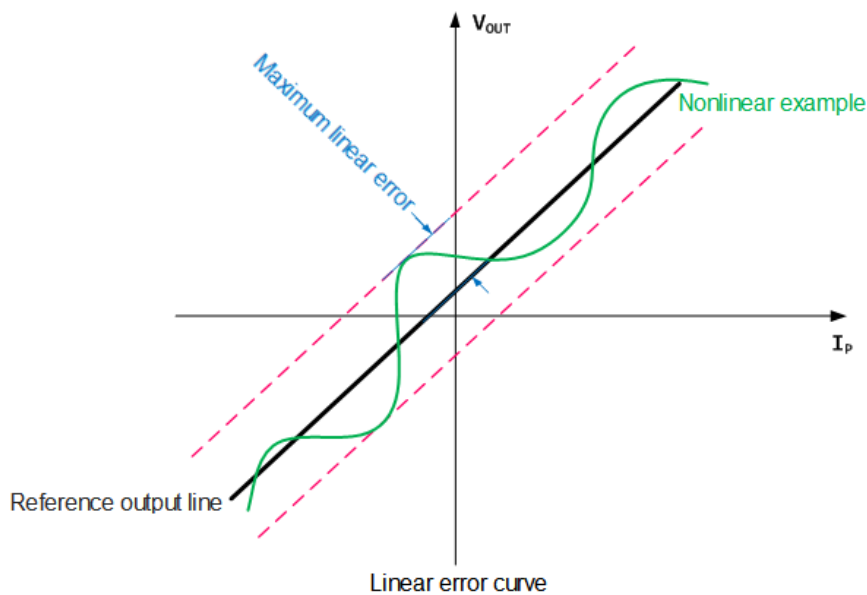

Notes:

1. Faulty wiring may cause damage to the sensor. After the sensor is connected to the 5V power supply, the measured current passes through the direction of the sensor arrow, and the corresponding voltage value can be measured at the output end.
2. TR mode: zero output voltage $V_{QVO} = V_{CC}/2$, the gain is fixed at 2V, and the output curve is: $V_{OUT} = V_{CC}/2 + 2 \times I_P/I_{P_MAX}$. A change in the supply voltage will cause a change in V_{OUT}
For example: V_{CC} range 4.75V to 5.25V-The output range of static output voltage V_{QVO} under the corresponding 0A is 2.375V~2.625V, and the range of full range output ($V_{OUT(I_{P_MAX})}$) is 4.375V~4.625V.
3. TF mode: zero output voltage $V_{QVO} = 2.5V$, the gain is fixed at 2V, the output curve is: $V_{OUT} = 2.5 + 2 \times I_P/I_{P_MAX}$; The change of supply voltage in a certain range will not cause the change of V_{OUT} .
For example: V_{CC} range 4.75V to 5.25V-The static output voltage V_{QVO} under the corresponding 0A is 2.5V; and the output of full range ($V_{OUT(I_{P_MAX})}$) is constant at 4.5V.



9. Packing Instructions

Terminals	Definitions
1	Vref
2	Vout
3	GND
4	VCC
E1-E4	GND

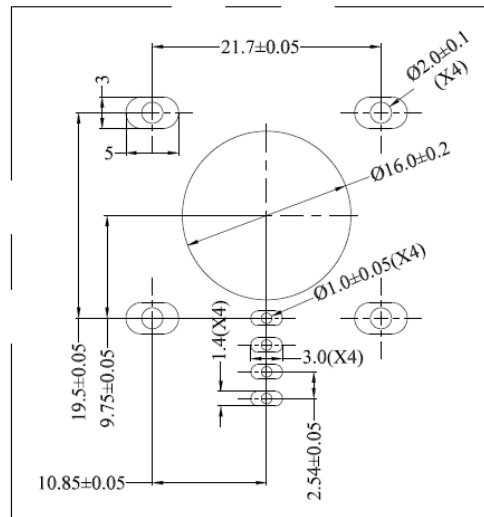
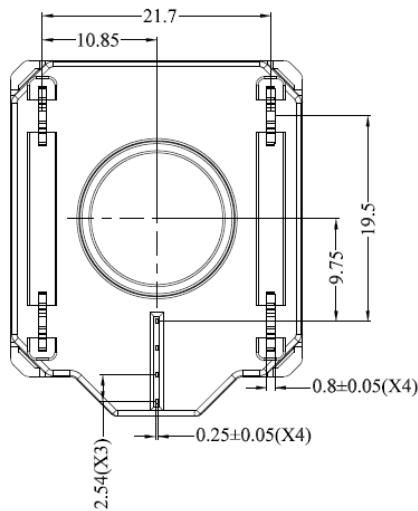
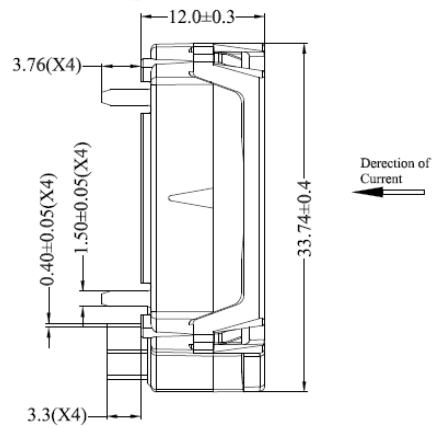
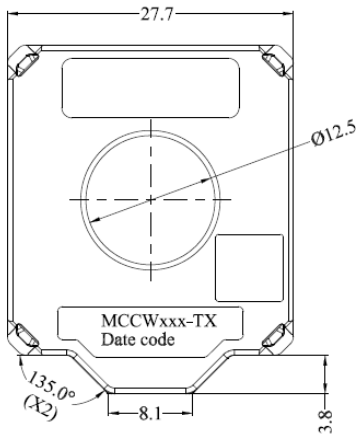
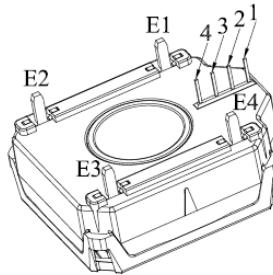

PCB Design Schematic



Copy Rights and Disclaimer

1. This document may not be reproduced or duplicated, in any form, in whole or in part without prior written consent of MIT . Copyrights © 2021, MIT-Magnetic Integrated Technology Incorporated.
2. MIT-Magnetic Integrated Technology reserves the right to make changes to the information published in this document at anytime without notice.
3. MIT's products are limited for use in normal commercial applications. MIT's products are not to be used in any device or system, including but not limited to medical life support equipment and system.